



## ASSEMBLY MANUAL



# ATTENTION!

SAFETY INFORMATION, INSTALLATION, CARE AND MAINTENANCE INSTRUCTIONS.  
READ PRIOR TO ASSEMBLING AND USING THE TRAMPOLINE.



# Contents

---

Read and follow all instructions in this manual before using your trampoline, and do not use the trampoline in any way that is not described in this manual.

Responsibility rests with the owner and supervisors of the trampoline to make sure that all users are aware of the practices specified in this manual.

1.0. Disclaimer.....	4
2.0. Care and Maintenance.....	5
2.1. General care .....	5
2.2. Rust and corrosion.....	5
2.3. Textile deterioration .....	5
2.4. Weather care.....	5
2.5. Relocation.....	5
2.6. Inspection checklist.....	6
3.0. Usage and Behaviour.....	6
3.1. Safe use information .....	6
3.2. Safe use instructions .....	7
3.3. Basic trampolining instructions.....	7
4.0. HexVex™ Games .....	8
5.0. Installation.....	9
5.1. Location planning .....	9
5.2. Parts checklist.....	9
5.3. Assembly instructions .....	10
6.0. Product registration .....	16
7.0. Half-price replacement parts .....	15
8.0. Warranty.....	16
8.1. Warranty periods.....	16
8.2. Inclusions .....	16
8.3. Exclusions .....	17
8.4. Warranty Claims.....	17
8.5. Australian Consumer Law .....	18
9.0. Missing parts.....	18

# 1.0. Disclaimer

---

The following Conditions of Sale will apply to, and bind the purchaser of, any Vuly Trampolines Pty. Ltd. ABN: 91 160 793 706 product.

## **NOTICE TO USER:**

Please read this agreement carefully before purchase or assembly. By purchasing, opening and assembling this product you acknowledge that you have read this agreement, understand it and agree to be bound by its conditions. If you are making a purchase on behalf of another person, you agree that you are making the purchase as their agent.

## **LEGAL RIGHTS – PLEASE READ:**

EXCLUSION OF LIABILITY – WAIVER OF RIGHT TO SUE – YOUR ASSUMPTION OF RISK – THESE CONDITIONS AFFECT YOUR LEGAL RIGHTS.

Vuly Trampolines Pty. Ltd. ABN: 91 160 793 706 (“Vuly”), as supplier of trampolines and accessories (“Products”), sells all Products subject to the following conditions:

1. To the maximum extent permitted by the law, Vuly, its employees, directors and agents will not be liable to the customer, their dependents or legal representatives for damage to property, personal injury or death suffered by the customer because the Product was not manufactured or supplied with due care and skill, the Product is not reasonably fit for its purpose or because of negligence, breach of contract, breach of statute or breach of statutory duty by Vuly.
2. Vuly, its employees, directors and agents are not liable to the customer, their dependents or legal representatives for personal injury or death suffered by the customer because the Product was not:
  - a. installed in accordance with the Vuly instruction manual. It is the customer’s responsibility to check all boxes to confirm that all components are included and in the correct condition before assembly.
  - b. installed with due care and skill, by a the customer or a third party assembly service; and
  - c. in the same condition as when the Product was supplied, due to wear and tear – including, but not limited to, weather damage, deterioration of the net, spring stretch, UV deterioration or rust.
3. The customer acknowledges that using the Product can be dangerous, with inherent risks and hazards. As a consequence, personal injury or death may occur. The customer assumes and accepts all such risks, and hereby – to the full extent permitted by law – waives the right of action against, and fully releases Vuly for, loss, damages, personal injury or death in any way caused by, or relating to, the customer’s participation in such activities.

This includes – without limitation – liability for any negligent or tortuous acts or omission, breach of duty, breach of contract or breach of statutory duty on the part of Vuly, its office bearers, directors, employees or agents.



## **RISK WARNING:**

The use of the Product involves a significant risk of participants suffering personal injury including the possibility of serious injuries, permanent disability or death. All participants who engage in activities with the Product do so at their own risk.

---

## 2.0. Care and Maintenance

Improper maintenance or lack of care can lead to your trampoline deteriorating earlier than expected. Please follow these care instructions to ensure that your trampoline lasts for as long as possible.

### 2.1. General care

- Inspect before and after each use. It is essential that you replace any worn, defective or missing parts immediately and only through Vuly.
  - See the 'Inspection checklist'.
- Ensure that the Safety Net (and Safety Pad, if applicable) is always correctly attached and in good condition.
  - Replace the Safety Net every 1 year.
- Keep away objects that could damage textile components.
- Ensure that moving metal components remain well lubricated.
- Use only Vuly-made accessories.
- Use only parts that are recommended by the manufacturer.

### 2.2. Rust and corrosion

- Be aware of areas that are particularly prone to rusting:
  - Places where water is easily trapped.
  - Hollow sections of steel (which can appear in good condition on the outside, while hiding rust on the inside).
  - Sections where different metal components join together.
- Inspect the inside of all Frame Tubes and Net Poles every 6 months – as well as after rain – and remove any water from the inside surfaces.
- Check Frame Tube and Net Pole connection areas for rust.
- Use general-purpose grease on steel connection areas.
- Avoid cleaning steel components excessively; it may reduce the effectiveness of our protective coatings.

### 2.3. Textile deterioration

- Clean your Jump Mat with a soft sponge only to avoid prematurely wearing the textiles.
- Avoid using powerful soaps or detergents; they can damage the textiles.
- Wipe dry with an absorbent cloth any water left after rain, cleaning or use of the Vuly Mister accessory. The mat may discolour or form spots, if left to dry in the sun.
- Inspect the inside of your Safety Pad (if applicable) regularly, and remove any water through the drainage holes.

- Remove textile parts, and store them – in their original packaging – in a cool, dry and dark place when the trampoline will be unused for over 1 month. Prolonged exposure to UV sunlight can shorten the lifespan of the safety net.

### 2.4. Weather care

Components of this trampoline are susceptible to deterioration from use and environmental conditions – such as sunlight, rain, salt and heat, to varying degrees.

If your trampoline will be unused for any extended period, disassemble it, return it to its original packaging and store it in a dry place.



**RAIN:** Remove any fallen debris on your trampoline after rain. Wipe off residual water with a dry cloth; moisture left on the trampoline may contribute to the corrosion of steel components and weaken textiles.



**WIND:** Disconnect the Safety Net from the Net Poles, and cover the Safety Net and Jump Mat with a storm cover.



**COLD:** Disassemble your trampoline.



**HEAT:** Move your trampoline to where it will receive the most shade during the brightest times of the day. Cover when not in use to minimise UV damage.

### 2.5. Relocation

- Move the trampoline with a minimum of 8 adults, to ensure that the lift is within heavy lifting regulations.
- Move the trampoline short distances using Vuly's official Wheels accessory, if your trampoline model supports it.
- Do not drag the trampoline. Joiner Poles and Frame Tubes may bend or warp if insufficiently lifted.
- Avoid tilting the trampoline or resting it on its side; the frame may bend under its own weight.
- Disassemble the trampoline, and return it to its original packaging, to transport it over long distances.

COMPONENTS WILL DETERIORATE OVER TIME.

Record your date of purchase here:

	/	/
---	---	---

## 2.6. Inspection checklist

Use this checklist to inspect your trampoline before each use. Replace any worn, defective, or missing parts to avoid potential hazards.

If you discover any safety issues, do not use the trampoline. Contact Vuly to order and replace any parts.

### Frame

- Bending, cracking, twisting or breakage of the Frame Tubes
- Rust spots
- Sharp protrusions

### Safety Padding

- Missing, improperly positioned or insecurely attached Safety Padding
- Punctures, frays, tears or holes in the Safety Padding
- Deterioration of the stitching or fabric of the Safety Padding and / or its securing system
- Damaged or degraded Safety Padding

### Springs

- Missing, broken or damaged springs

### Jump mat

- Punctures, frays, tears or holes in the bed or the edge system
- Deterioration in the stitching or fabric of the bed or edge system
- Sagging fabric
- Sharp protrusions in the suspension system elements
- Broken mat connector plastics
- Rusting, damaged or bent mat connector steel

### Safety net

- Missing, improperly positioned or insecurely attached enclosure barrier
- Punctures, frays, tears or holes in the enclosure barrier or connectors
- Deterioration in the stitching or fabric of the enclosure barrier or connectors
- Sagging of the enclosure barrier
- Broken or damaged enclosure entry system

### Net poles

- Missing, improperly positioned or insecurely attached:
  - A. Net Pole supports
  - B. Net Pole caps
- Bending, cracking, twisting or breakage of the Net Pole supports
- Rust spots on the Net Pole supports
- Sharp protrusions from the Net Pole supports

## 3.0. Usage and Behaviour

Improper use of, or behaviour on, your trampoline can lead to serious injury. Please follow these usage and behaviour instructions to ensure safe play.

### 3.1. Safe use information

Trampolines are great fun, encourage the development of gross motor skills; provide opportunities for physical activity and present users with manageable challenges to find and test their limits. However, like many physical activities, trampoline use involves potential risk of injury, particularly if the equipment is used improperly.

Injury surveillance and hospital admissions data show that trampolines feature frequently in injury presentations and admissions. Children under 14 years of age account for about 90% of all trampoline-related injuries. 28% of the trampoline-related injuries were sustained by children under five years of age and more than a third of the injuries related to multi-users. (Victorian Injury Surveillance Unit—Hazard 75, Autumn 2013, pg. 3.)

The following points are important to note:

- Injury data indicates that people can be severely injured if they land on an unprotected trampoline frame or springs or if they fall from the trampoline. Impact attenuation systems, such as pads, are intended to minimise the risk of injury and enclosures are intended to stop people falling off the trampoline.
- Ensure that your enclosure is attached to the trampoline before use.
- The risk of injury increases when more than one person at a time bounces on a trampoline. Smaller children are at increased risk when jumping with adults and/or larger children, for example, a 'double bounce' dramatically increases the energy transferred to the smaller body and children's legs have been broken and severe spinal injuries have occurred as a result.
- Ensure that only one person at a time bounces on the trampoline
- Children are often unable to identify hazards and do not have a well-developed ability to assess risk and may, if left unsupervised, be at more risk of injury.
- Always supervise children while they are using the trampoline
- Overconfidence can lead to injury.
- Learn fundamental bounces first before trying more complex manoeuvres.
- Inappropriate clothing can cause injury.

- Clothing should allow plenty of body movement without flapping loosely and becoming a distraction to the jumper.
- Wear clothing free of drawstrings, hooks, loops or anything that could get caught while using the trampoline and result in entanglement or strangulation. Buckles, jewellery and belts should not be worn, as these may damage the trampoline mat or cause injury to the jumper if they become caught in the fabric of the trampoline.
- Should be removed as they may damage the bed and increase the risk of injury.

Better design, good construction and improved safety features go a long way towards minimising the hazards associated with trampoline use; however, trampolines need to be used, cared for and maintained appropriately to ensure the benefits of these features continue throughout the life of the product.

### 3.2. Safe use instructions

- To reduce the risk of injury while using the trampoline, develop household rules – such as the following:
- Do not allow children under 6 on the trampoline.
- Allow only one person on the trampoline at any one time.
- Active, competent supervision is essential – always supervise children while they are using the trampoline.
- Ensure that any pads (where they are required) covering the frame / suspension system are securely attached at all times.
- Ensure that the enclosure is securely attached and in good condition at all times.
- Check the trampoline before use and ensure that it is in good condition. Replace any worn or broken parts. Use only parts that are produced by Vuly.
- Make sure that the area around, underneath and above the trampoline is clear of objects that could interfere with the person jumping. Do not allow children, pets, toys or other play equipment to be present under the trampoline.
- Adults should model safe use of trampolines when children are present.
- Wear comfortable clothing that won't become entangled in the trampoline's components and become a strangulation hazard. Do not wear jewellery or drawstrings / cords that can catch on the trampoline and create a strangulation hazard. Remove shoes, as they may damage the bed and increase the risk of injury.
- Children should be educated by responsible adults

to always climb on and off the trampoline, and never jump or bounce off. It is dangerous practice to jump or bounce from the trampoline when dismounting. Never use springs or suspension elements as 'hand grips' when getting on and off the trampoline.

- Learn fundamental bounces and body positions thoroughly before trying more advanced manoeuvres. A variety of trampoline activities can be carried out by performing the basic fundamentals in various series and combinations, or performing one fundamental bounce after the other, with or without bounces between them.
- For further information or additional instructional material, contact Vuly or an authorised retailer. To learn more advanced trampolining skills, contact a suitable gymnastics / trampoline club.

### 3.3. Basic trampolining instructions

This trampoline is a domestic trampoline, not a gymnastics trampoline. You will get the safest and best use from it by following these basic principles:

- Do not attempt or allow somersaults on the trampoline. Landing on your head or neck while doing somersaults can cause serious injury, paralysis or even death.
- Do not use the trampoline when wet. The mat will be slippery and make landing less secure.
- Enclosure systems are designed to prevent users falling off the trampoline. Do not allow users to intentionally bounce towards or off the barrier, as this can unbalance the trampoline and continual impact may damage the enclosure.
- Do not use a trampoline while under the influence of alcohol or drugs. Balance, perception and assessment of risk will be affected and may lead to injury.
- Do not use the trampoline as a springboard to other objects. Use the trampoline only for trampoline-style bouncing.
- Focus your eyes on the edge of the trampoline. This will help control your bounce.
- Stop your bounce by flexing your knees as your feet come in contact with the trampoline bed. Learn this skill before you attempt any others.
- Avoid bouncing too high. Stay low until you can control your bounce and repeatedly land in the centre of the trampoline.
- Do not bounce immediately after a meal.

## 4.0. HexVex™ Games

HexVex™ is a unique, interactive game printed right on your Jump Mat! Originally based on 'Add-ons' - a training tool used by elite trampolinists to improve their coordination and reaction time - HexVex™ helps jumpers to improve their balance and enhance their memory and learn sequence.

Invent new games with HexVex™, and tell Vuly to have them published for everyone to enjoy!

### Match-up

Players: 2

The first player starts in the middle of the Jump Mat, and begins the game by picking an icon and jumping onto it. They then jump to the other, matching icon. That player continues this process, choosing and matching up all nine icons to complete one round. A miss-matched jump ends their turn in the game.

The winner is the first person to complete three consecutive rounds of matched icons!

### Mimic Me!

Players: 2 or more (in pairs)

The first player starts in the middle of the Jump Mat, with their partner standing outside the trampoline. The partner writes down the names of all the HexVex™ icons (in an order of their choosing). They begin the game by calling out each icon name, and the bouncer must jump onto them.

Once the partner has called all of the icons, the bouncer must try to do the sequence again from memory. If they get it wrong, they end their turn and trade places.

The winner is the first player to fully mimic a sequence from memory!

### HexVex™ players

A trampoline should be used by one person at a time. Some HexVex™ require more than 1 person to play.

For each of these games that requires bouncing, a player should climb off the trampoline to allow the next player to have their turn. For those games that do not require standing or bouncing, exercise caution while playing.

### Story Hop

Players: 2-3

The first player starts in the middle of the Jump Mat, and begins the game by jumping on any icon, and shouting a part of a story that relates to that icon. That player then continues the story by jumping on the remaining icons to tell a complete story. The other players then take their turns by doing the same.

The winner is the player who achieves the most laughs with their story from all the other players!

### Musical Icons

Players: 4 - 5 S or M sizes | 6 - L or XL sizes

by Donna and Hayley Shaw, winners of Create-a-HexVex™ Game.

Each player hops into the trampoline and puts on a blindfold. The supervising parent then plays some music, and each player crawls around on the HexVex™ Game Mat, wiggling and dancing until the referee stops the music. When they do, each player must sit up on their knees and lift up their blindfold to see if both of their knees are on a HexVex™ icon. If they're not, that player is out.

The winner is the last player left wiggling!





## 5.0. Installation

### 5.1. Location planning

- Place the trampoline on a flat, level surface with impact attenuating properties – such as grass.
- Ensure that the trampoline is sufficiently stable, to prevent the trampoline from tipping over or blowing away. Sandbags or pegs may be suitable anchorage devices.
- Keep a minimum of 8 m overhead clearance, when measured from the bed height, to prevent users from inadvertently contacting overhead hazards – such as electric wires, tree limbs and clotheslines.
- Maintain a minimum clearance of 2 m on all sides of the trampoline. This area should not include concrete, bitumen, brick or other hard surfaces, as these can cause serious injuries if users fall off the trampoline.
- Do not locate the trampoline on top of other objects or store anything underneath the trampoline bed.
- Keep the area around and underneath the trampoline clear. Place the trampoline away from walls, structures, fences and other play areas.
- Place the trampoline in a well-lit area.

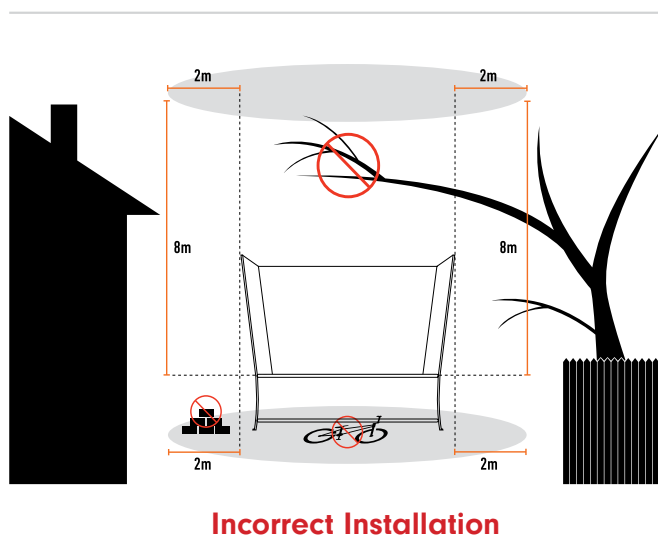
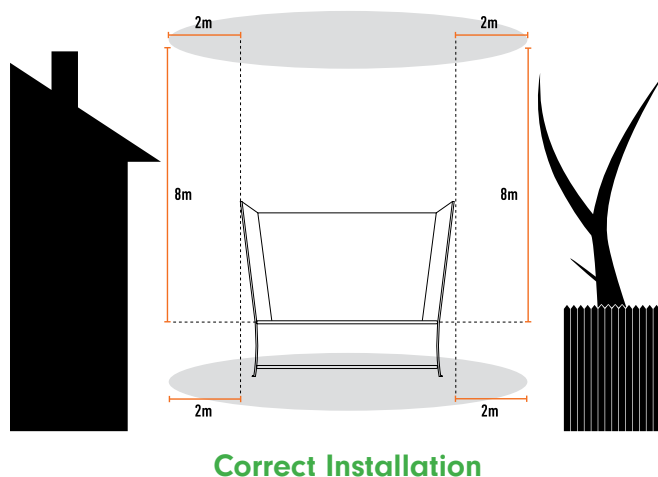

### 5.2. Parts checklist

<b>S</b>	<b>1x BOX A</b> (L) 1200mm (W) 470mm (H) 245mm	<b>1x BOX B</b> (L) 1140mm (W) 385mm (H) 215mm		
	<b>Frame tubes, Springs, Safety pad, Jump mat</b>	<b>Net poles, Joiner poles, Safety net</b>		
<b>M</b>	<b>1x BOX A</b> (L) 760mm (W) 390mm (H) 460mm	<b>1x BOX B</b> (L) 1000mm (W) 470mm (H) 165mm	<b>1x BOX C</b> (L) 1140mm (W) 280mm (H) 240mm	
	<b>Frame tubes, Safety pad</b>	<b>Joiner poles, Springs</b>	<b>Net poles, Safety net, Jump mat</b>	
<b>L</b>	<b>1x BOX A</b> (L) 800mm (W) 425mm (H) 180mm	<b>1x BOX B</b> (L) 1000mm (W) 415mm (H) 225mm	<b>1x BOX C</b> (L) 1140mm (W) 300mm (H) 200mm	<b>1x BOX D</b> (L) 760mm (W) 360mm (H) 400mm
	<b>Frame tubes</b>	<b>Joiner poles, Jump mat</b>	<b>Net poles, Safety net</b>	<b>Safety pad, Springs</b>
<b>XL</b>	<b>1x BOX A</b> (L) 870mm (W) 460mm (H) 410mm	<b>1x BOX B</b> (L) 800mm (W) 330mm (H) 220mm	<b>1x BOX C</b> (L) 1140mm (W) 310mm (H) 205mm	<b>1x BOX D</b> (L) 1000mm (W) 500mm (H) 215mm
	<b>Upper frame tubes, Safety pad</b>	<b>Lower frame tubes, Springs</b>	<b>Net poles, Safety net</b>	<b>Joiner poles, Jump mat</b>

## VULY LIFT

Check that your trampoline bundle contains the all of following parts:

**TIME REQUIRED FOR ASSEMBLY: 1 HOUR (APPROX).**  
**NUMBER OF PEOPLE REQUIRED FOR ASSEMBLY: 2**

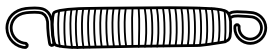

Springs

S	M	L	XL
48	63	72	90

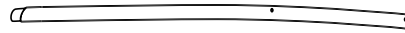

Upper net poles

S	M	L	XL
6	7	8	9



Jump mat

S	M	L	XL
1	1	1	1



Upper frame tubes

S	M	L	XL
6	14 (7xA, 7xB)	16 (8xA, 8xB)	18 (9xA, 9xB)

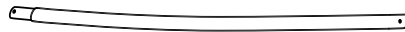

Lower net poles

S	M	L	XL
6	7	8	9



Safety net

S	M	L	XL
1	1	1	1



Lower frame tubes

S	M	L	XL
6	14 (7xA, 7xB)	16 (8xA, 8xB)	18 (9xA, 9xB)

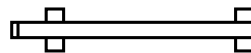

Joiner poles

S	M	L	XL
6	7	8	9



Spring tool

S	M	L	XL
1	1	1	1

### 5.3. Assembly instructions – Vuly Lift

#### PRE-ASSEMBLY

- Find level ground, and make sure that there are no obstructions nearby.
- Check that you have all the parts required for assembly.

**REMEMBER:** WEAR THE VULY GLOVES AT ALL TIMES WHEN INSTALLING YOUR TRAMPOLINE.



Keep the Leaf Spring sleeves on during assembly and over the life of your trampoline. These sleeves provide crucial protection in the unlikely event of a Leaf Spring breaking.

**STEP | 1**

**M, L AND XL MODELS ONLY**

- A. Connect each Lower Frame Tube A to a Lower Frame Tube B. Lower Frame Tubes are those without spring holes or square ends.
- B. Connect each Upper Frame Tube A to an Upper Frame Tube B. Ensure that the push buttons lock these components together.

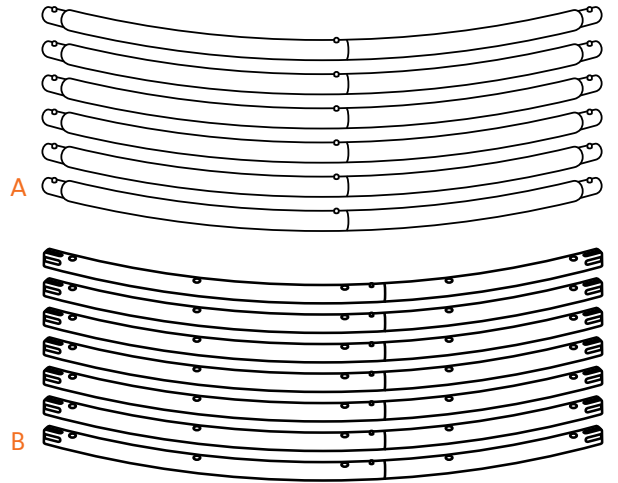
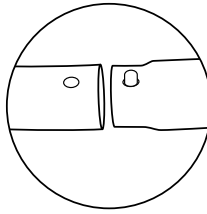

**STEP | 2**

- A. Lay out each Lower Frame Tube in a circle. Place the Upper Frame Tubes around them. Ensure that all push buttons are on the left-hand side of their middle connection and that all ends face the same direction.

**Note:** If all push buttons are not on the left half of the connected Upper Frame Tubes and the ends of the Lower Frame Tubes do not face the same direction, the Frame and Springs will not attach correctly.

- B. Position each Joiner Pole in the gaps around the Frame Tubes.

**Note:** The feet of the Joiner Poles must face outwards and the joiner connector inwards.

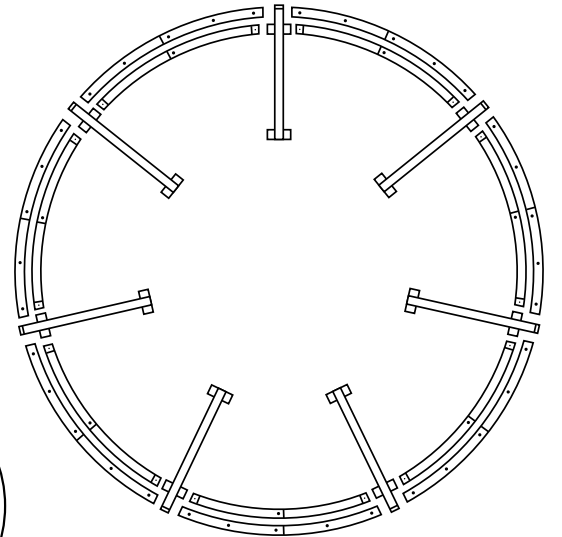
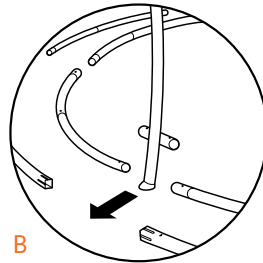

**STEP | 3**

- A. Choose a Joiner Pole. Slide Lower Frame Tubes into both sides of it and an Upper Frame Tube on the left side only.
- B. Go around your trampoline, connecting the Upper and Lower Frame Tubes to each Joiner Pole until you complete the frame. Ensure that all push buttons properly lock.
- C. See that your completed frame matches the image.

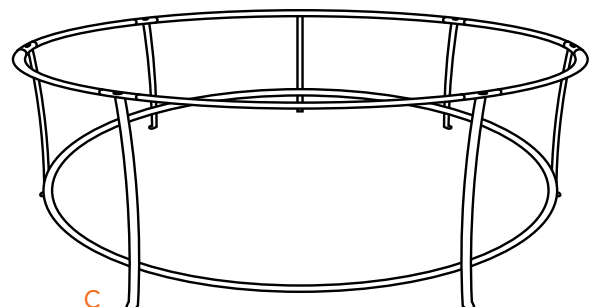
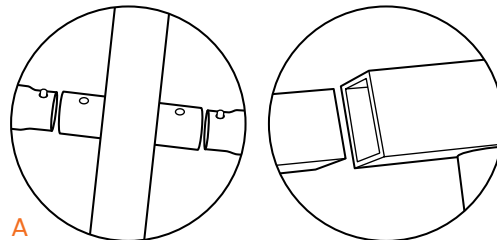

## Mat and springs

### STEP | 4

- A. Unravel and lay your trampoline Mat inside the frame, ensuring that it is flat, with the print facing upwards.
- B. Find the Vuly Batch Tag on the Mat, and rotate the Mat so that the Batch Tag lines up with a Joiner Pole.

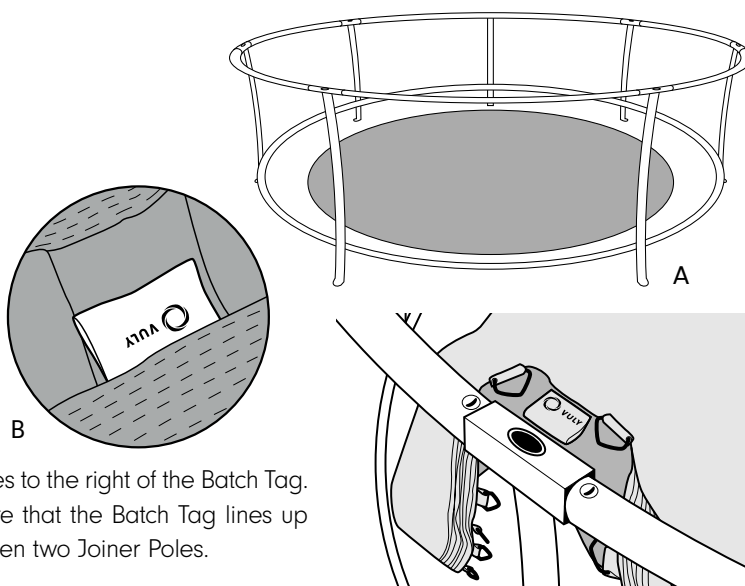

**Note:** The net entrance will be between the two Joiner Poles to the right of the Batch Tag. Rotate your Mat to the desired position, but always ensure that the Batch Tag lines up with a Joiner Pole. The Vuly logo should be centred between two Joiner Poles.

### STEP | 5

- A. Attach a Spring into the D-shackle that is on the right of the Batch Tag, and connect it to the Spring hole directly on the right of a Joiner Pole.

Note: You must hook the short ends of the Spring hooks into the D-shackles on the Mat, and hook the long ends into the Frame.

- B. Go to the opposite side of the frame - counting Springs against D-shackles as you go - and connect a Spring to the right of the opposite Joiner Pole to its corresponding D-shackle.

**Tip:** Hooking the Spring to the Mat and pulling back to the Frame is the easiest connection method. Alternatively, use the Spring tool to pull and connect the Springs from the Mat to the Frame.

- C. Repeat for each Spring and D-shackle to the right of every Joiner Pole. Then, repeat for each Spring to the left of each Joiner Pole.

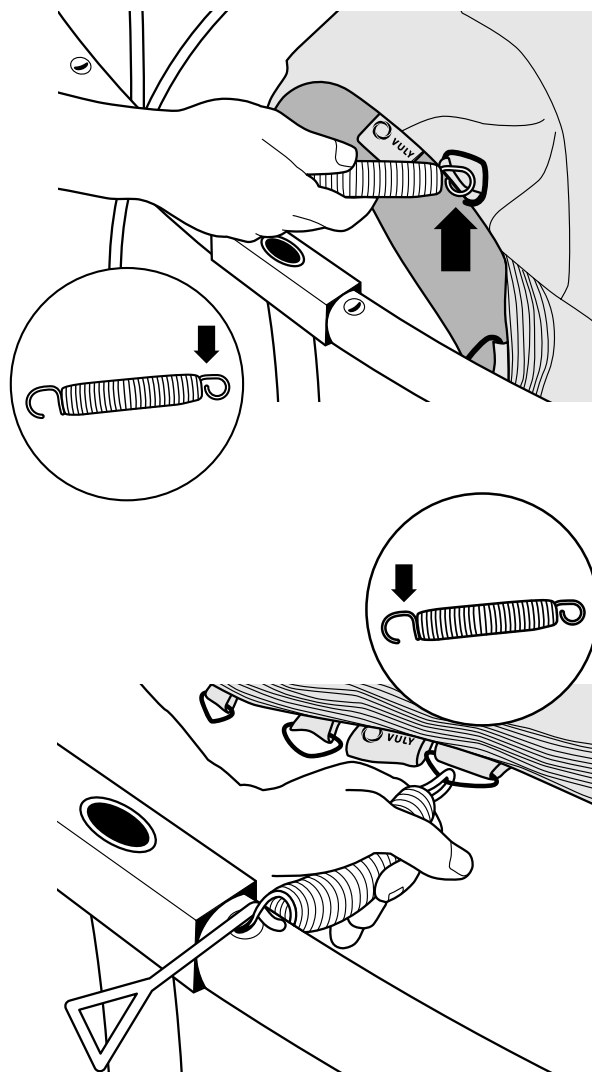
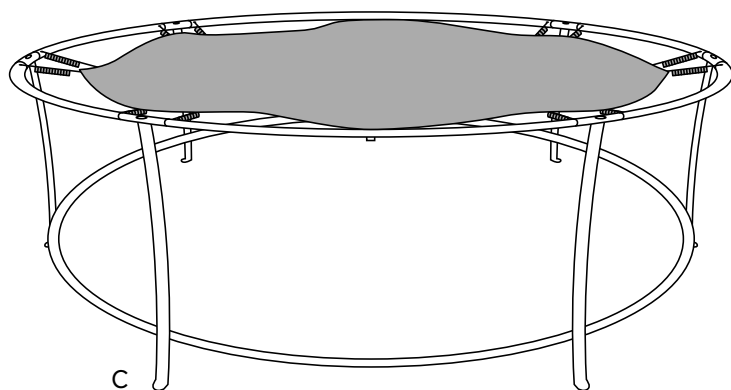

## Safety Net

### STEP | 6

- Unravel your Safety Net and lay it atop your trampoline mat.
- Find the the Vuly Batch Tag on the Safety Net, and rotate the Net so that this Batch Tag lines it up with the one on the Mat. Ensure that the PP belts on the Safety Net are on the outside and that they also line up with the Joiner Poles.

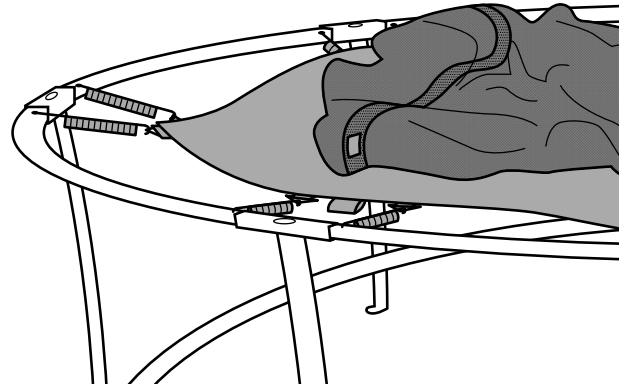

### STEP | 7

- Unhook the D-shackle to the right of the Batch Tag. Slip it through the net connector hole to the right of the PP belt, before re-attaching it to the Net and Frame. Do the same for the D-shackle to the left of the Batch Tag.
- Repeat for each Spring and D-shackle to either side of every Joiner Pole.

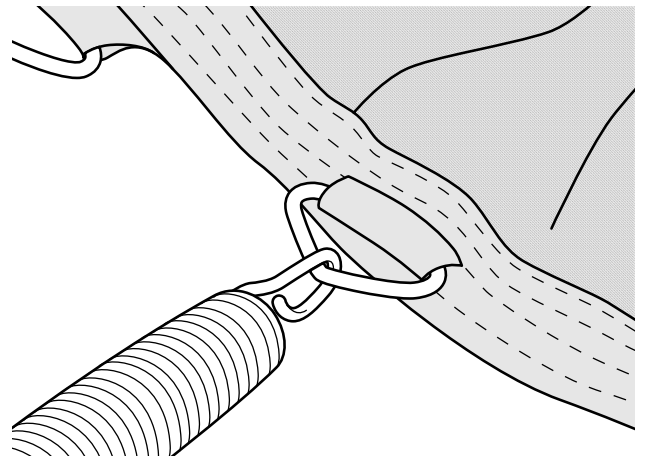

### STEP | 8

Make your way around the Frame, slipping all D-shackles through their corresponding net connector holes.

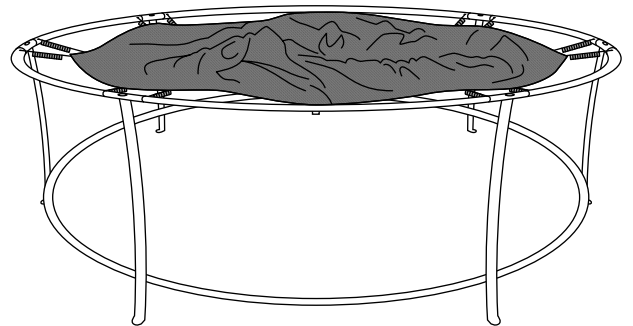

### STEP | 9

Go around your trampoline, attaching one Spring per Frame section to the Mat and pulling it into the Spring holes on the Frame. Ensure that the D-Shackles remain slipped through the net connector holes as you do so.

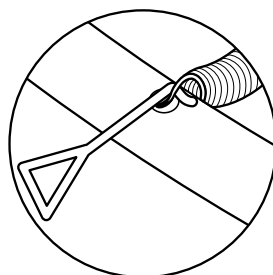

**Remember:** Spring holes alternate between atop and beneath the Upper Frame.

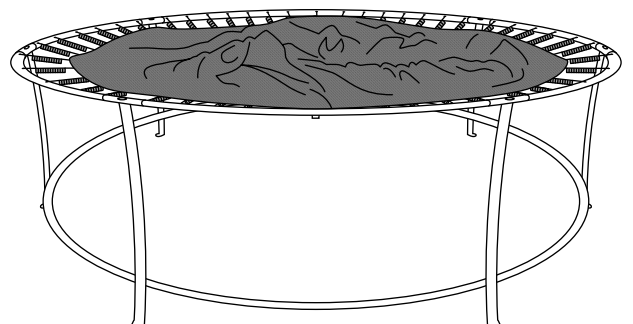

## Safety Padding

### STEP | 10

Place the Safety Padding onto the Mat and Safety Net. Unfold and position it to cover the Springs. Ensure that all openings in the Safety Padding are over the Net Pole holes in the Joiner Poles and that the Vuly logo lines up with the entrance.

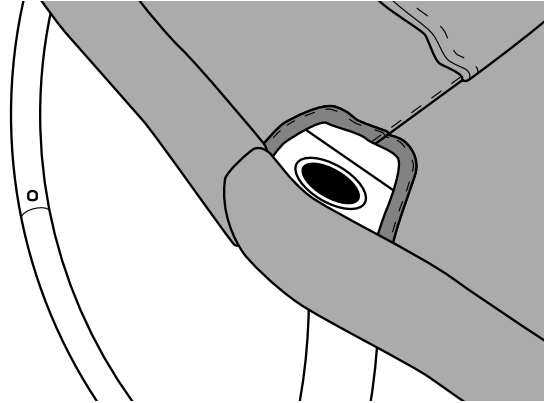

### STEP | 11

- Lift up the Safety Padding, and completely remove the Spring to the left of a Joiner Pole. Feed the Spring through the loop on the Safety Padding, before re-hooking it to the Mat and Frame.
- Repeat for each Spring and loop in the Safety Padding to the left of every Joiner Pole.

**Remember:** Ensure that the Safety Padding is correctly attached and secured. Properly installed Safety Padding is crucial to protect against injuries.

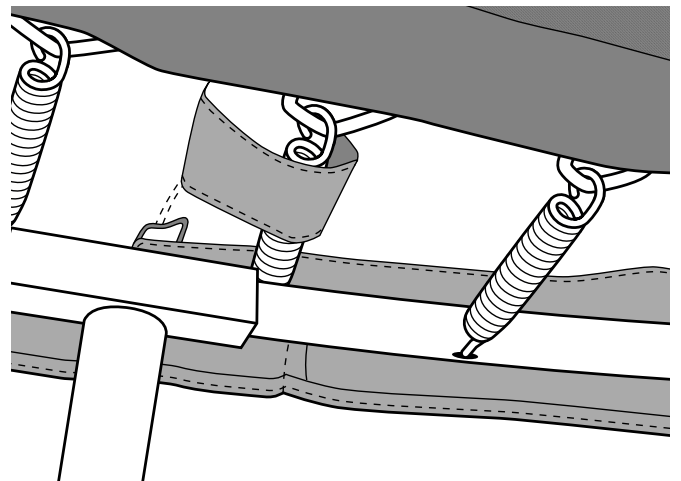

## Net poles

### STEP | 12

- Insert each Upper Net Pole into each Lower Net Pole. The Lower Net Pole is reinforced at the bottom.
- Rest the completed Net Poles against the frame at each Joiner Pole.

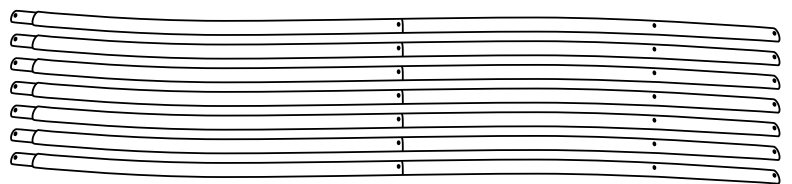

A

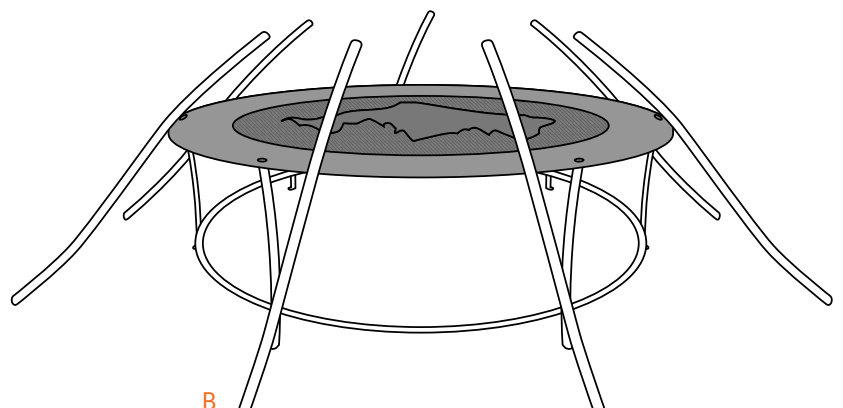
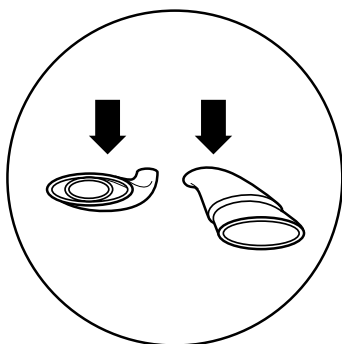

B

## STEP | 13

- A. Insert each Net Pole Plug into every Upper Net Pole. Ensure that the materials are not twisted and that the Upper Net Pole is facing outwards.

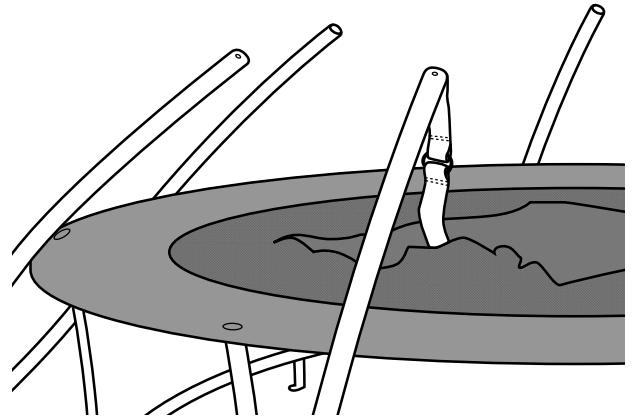
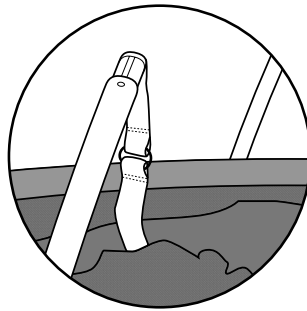

## STEP | 14

- A. Lift the Net Pole, raising the net at the same time. Insert it into the Joiner Pole through the holes in the Padding.
- B. Repeat for each Net Pole until you have completely erected the Safety Net.

Remember: Ensure that the Safety Net is correctly assembled. A properly installed Safety Net is crucial to protect against injuries.

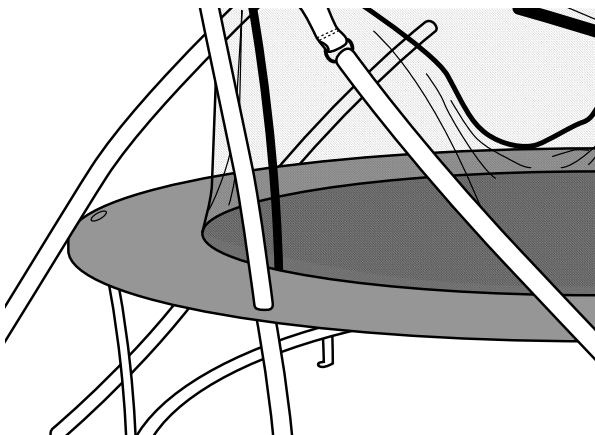
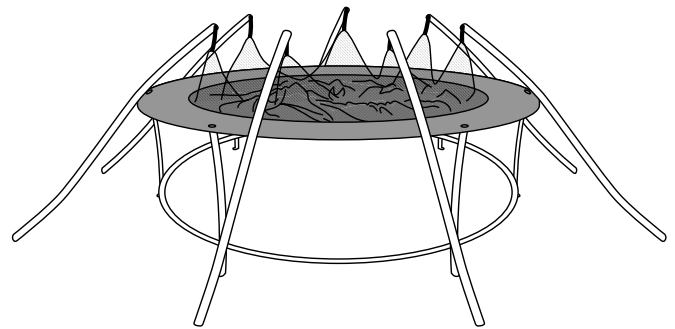

A

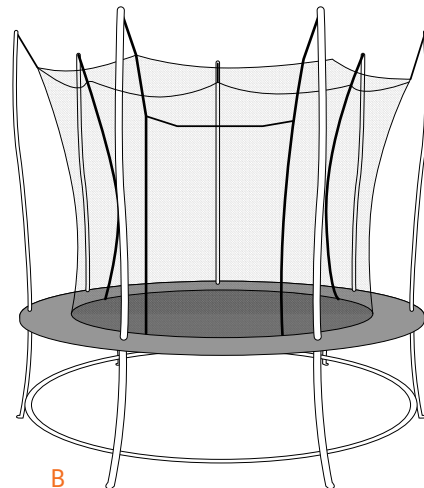

B



**WARNING:** Make sure that all push buttons are locked and secured before using your trampoline. Bouncing on a trampoline with push buttons that are not locked will cause damage and injury.



# CONGRATULATIONS!

You have finished assembling your Lift trampoline.



## 6.0. Product registration

To access the Half-Price Parts for Life programme or to lodge a Warranty Claim, customers must ensure that their Vuly product is registered with Vuly.

Whether the customer purchased their Vuly product through Vuly's website, at the Brisbane showroom, over the phone or through an authorised resellers, they must register their product by visiting [www.vulyplay.com/support](http://www.vulyplay.com/support) and completing the form with a proof of purchase.

## 7.0. Half-price Replacement Parts

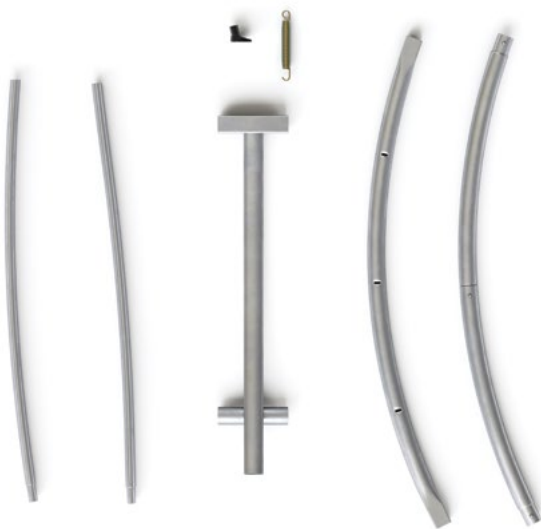

Vuly offers half-price replacement parts to all customers for the lifetime of their trampoline purchase through the Half-Price Parts for Life programme.

This programme is subject to change at any time, and it is only available to customers who have purchased either through an authorised reseller or directly through Vuly.

Half-Price Parts for Life is only available to customers who wish to replace parts that are core components of their trampoline. These parts include:

- Springs,
- Leaf Springs,
- Jump Mat,
- Joiner Poles
- Safety Net (and components thereof),
- Net Poles,
- Frame Tubes.

The programme does not extend to accessories or to Tent components.

## 8.0. Warranty

All Vuly products are sold with a manufacturing warranty, which assure that the item is free of defects in workmanship and materials ("warranty").

Vuly offers the longest and most extensive warranties in the market on all our trampoline models. We provide comprehensive after-sales service, which we believe encourages the customer to purchase a Vuly trampoline instead of those of our competitors.

### 8.1. Warranty periods

Warranty periods do not reset for any reason, unless the customer purchases a new product. In this case, that particular item will be covered by its own warranty period. It does not affect – nor will it increase – warranty periods for other purchased items.

Warranty periods always commence from the date of item delivery.

This warranty is for use under normal conditions, and it applies for:

#### Trampolines

- 120 months [10 years] to the Frame Tubes and Joiner Poles.
- 60 months [5 years] to the Springs (excluding Leaf Springs), and Jump Mat (excluding the print).
- 12 months [1 year] to all other parts of a purchased trampoline – e.g. Safety Pad, Safety Net, Net Poles and Leaf Springs.

#### Accessories

- 12 months [1 year] to purchased accessories – e.g. Mister, Deck – not received during a promotional period.
- 3 months to any items received at no cost as part of a promotion – e.g. 'Free Shade Cover'.

The customer may extend the standard 12-month [1 year] warranty to 36 months [3 years], if they purchase an extended warranty within 7 days of their delivery date.

### 8.2. Inclusions

This warranty covers manufacturing faults and defects only.

If a product is damaged or rendered unsafe as a result of a departure from its design specifications during production, this constitutes a manufacturing fault or defect.

This may occur if – for example – use of incorrect textiles during manufacturing causes a Safety Net to disintegrate, or if improper welding produces an unstable Frame.



## 8.3. Exclusions

### 8.3.1. Damage through wear and tear

This warranty does not extend to normal wear and tear of the product. This may include, but is not limited to:

- Rusting of steel components,
- UV deterioration of textile components,
- Stretching of springs.

As outdoor products that are actively used, trampolines and their accessories will experience wear and tear over time.

### 8.3.2. Damage through weather conditions

Damage to the product that results from weather events – such as rain or wind – are not covered under the warranty. Vuly suggests that you contact your home and contents insurer if your trampoline is damaged by such events.

### 8.3.3. Damage through improper installation

This warranty does not extend to any failure of the product caused by installation not in accordance with the Vuly Manual. Customers must assemble their Vuly product by following carefully the Installation section of their Vuly Manual.

Furthermore, the warranty does not cover installation provided by a third-party assembly service. It is the customer's responsibility to check all boxes and confirm that all components are included in the correct condition before installing.

### 8.3.4. Damage through insufficient care or maintenance

This warranty does not extend to accelerated decay of the product caused by poor care or maintenance. It is essential that customers regularly check, and follow the advice of, the Care and Maintenance sections of their Vuly Manual to ensure that their product lasts as long as possible.

### 8.3.5. Damage through inappropriate use

This warranty will be void if the product is used for any other activity besides those for which it was intended. Vuly products constitute recreational trampolines and accessories for such trampolines. They are not intended for use as professional, gymnastics trampolines, springboards, etc.

Any evidence that inappropriate actions that have led to product failure will not be covered by the warranty. Similarly, replacement parts or repairs needed to mend such damage will not be covered under the warranty.

### 8.3.6. Personal Injury

The warranty does not cover personal injury or losses due

to any of the above: wear and tear, weather conditions, inappropriate installation, insufficient care or maintenance or inappropriate use, nor does it cover damage due to negligence or accidents.

## 8.4. Warranty Claims

If a customer believes that a Vuly product is faulty or defective, they must discontinue use and submit a Warranty Claim.

A customer must not attempt to use a product if any part is faulty or defective, as it may be dangerous. Any damage that the user causes as a result of using faulty or defective products will lead to voiding of the warranty.

### 8.4.1. Making a Warranty Claim

To fulfil a warranty claim, a customer must submit an online Warranty Claim at [www.vulyplay.com/support](http://www.vulyplay.com/support).

Submitting the online Warranty Claim form requires the customer to provide:

- Details of their purchase – including date,
- Batch number,
- Clear photographic evidence of the manufacturing fault or defect.

If the customer does not provide all details that the form requires, their Warranty Claim will not be assessed.

Vuly may take up to 7 days to process Warranty Claims upon a completed submission. It may take a further 7 days for replacement parts to reach the customer.

### 8.4.2. Successful Warranty Claims

If Vuly accepts a customer's Warranty Claim, Vuly will replace the faulty or defective parts, not offer refunds.

*Successful Warranty Claims lodged within 7 days of the delivery date*

Vuly will replace the damaged parts free of charge. Vuly will also cover any costs associated with shipping the replacement part.

*Successful Warranty Claims lodged after 7 days of the delivery date*

Vuly will replace the damaged parts free of charge. The customer must cover any costs associated with shipping the replacement part.

### 8.4.3. Refunds

In all instances of successful warranty claims, Vuly offers replacements parts only. Vuly provides refunds only at their discretion.

#### 8.4.4 Claiming on non-Vuly products

Products sold alongside Vuly that are not Vuly-branded are subject to the warranties provided by the companies that supply them. The customer must contact these external companies to make a warranty claim; Vuly itself will not assess claims made against non-Vuly products.

#### 8.5. Australian Consumer Law

Our Goods come with guarantees that cannot be excluded under the Australian Consumer Law. You are entitled to a replacement or refund for a major failure and for compensation for any other reasonably foreseeable loss or damage. You are also entitled to have the Goods repaired or replaced if the Goods fail to be of acceptable quality and the failure does not amount to a major failure.

### 9.0. Missing parts

If a customer believes that a Vuly product does not include all necessary parts, they must immediately lodge a Missing Parts Claim at [www.vulyplay.com/support](http://www.vulyplay.com/support).

A customer must not attempt to use a product if any part is incomplete, as it may be dangerous. Any damage that the user causes as a result of using incomplete products will lead to voiding of the warranty.

Vuly trampolines are delivered to Vuly HQ prepackaged; we are unable to check the boxes prior to delivery to ensure that they contain all the required parts. While the missing part rate during packing is very low, some parts may also fall out in transit due to small, unintentional tears in their boxes.





See [vulyplay.com/terms](https://vulyplay.com/terms) for the most recent Vuly warranty policies, terms and conditions.