

 **VULY** | Slam Pro[®] (Portable)

ASSEMBLY MANUAL



ATTENTION!

SAFETY INFORMATION, INSTALLATION AND USE INSTRUCTIONS.
READ PRIOR TO ASSEMBLING AND USING THE BASKETBALL HOOP.

2-PERSON ASSEMBLY

Contents

Read and follow all instructions in this manual before using your basketball hoop, and do not use the basketball hoop in any way that is not described in this manual.

Responsibility rests with the owner and supervisors of the basketball hoop to make sure that all users are aware of the practices specified in this manual.

1.0. Care, Maintenance and Safe Usage	4
2.0. Installation	5
2.1. Pre-assembly	5
2.2. Parts checklist	5
2.3. Assembly instructions - Vuly Slam Pro	5
3.0. Product registration	11
4.0. Half-price replacement parts	11
5.0. Warranty	
5.1. Warranty periods	11
5.2. Inclusions	11
5.3. Exclusions	11
5.4. Warranty Claims	11
5.5. Australian Consumer Law	11
6.0. Missing parts	13

1.0. Care, Maintenance and Safe Use

IMPROPER INSTALLATION OR SWINGING ON THE RING MAY CAUSE SERIOUS INJURY OR DEATH.

Save this instruction and contact Vuly on **1300 667 514** in the event that you require replacement parts. Your model is **BAS100**.



WARNING:

FAILURE TO FOLLOW THESE WARNINGS MAY RESULT IN SERIOUS INJURY AND/OR PROPERTY DAMAGE AND WILL VOID WARRANTY.

Owner must ensure that all players know and follow these rules for safe operation of the system.

- Only hang from the rim briefly to regain balance or avoid injuring others. Release the rim as soon as safely possible.
- During play, specially when performing dunk-type activities, keep players' faces away from the backboard and rim, and net. Serious injury could occur if teeth / face come in contact with backboard, rim, or net.
- Do not slide, climb, or play on base or pole.
- Completely fill base according to manufacturer instructions or the system will tip quickly, causing serious personal injury.
- When adjusting height or moving system, keep hands and fingers away from moving parts.
- Do not allow children to move or adjust system.
- During play, do not wear jewelry (rings, watches, necklaces, etc.). Objects may entangle in net.
- Surface beneath the base must be smooth and free of gravel or other objects. Punctures can cause leakage and could cause the system to tip over.
- Keep water and organic material away from pole. Pole can rust and fall.
- Once a month, check the pole and all metal parts for rust. Completely remove rust and repaint with exterior enamel. If rust has penetrated any steel part, replace that part immediately.
- Check the system before each use for proper ballast, loose hardware, instability, and signs of corrosion and repair before each use. Never play on damaged equipment.
- Do not use the system during windy or severe weather. System may tip over. Place the system in an area protected from the wind or in an area away from property that may be damaged if the system falls.
- Clean away any dirt or grime when present.



**ADULT SUPERVISION IS REQUIRED AT ALL TIMES WHILST EQUIPMENT IS IN USE.
VULY CARES ABOUT SAFETY.**

2.0. Installation

SAFETY INSTRUCTIONS



WARNING:

FAILURE TO FOLLOW THESE WARNINGS MAY RESULT IN SERIOUS INJURY AND/OR PROPERTY DAMAGE AND WILL VOID WARRANTY

Owner must ensure that all players know and follow these rules for safe operation of the system.

To ensure safety, do not attempt to assemble this system without following the instructions carefully. Check entire box and inside all packing material for parts and/or additional instruction material. Before beginning assembly, read the instructions and identify parts using the hardware identifier and parts list in this document.

Proper and complete assembly, use, and supervision are essential for proper operation and to reduce the risk of accident or injury. A high probability of serious injury exists if this system is not installed, maintained, and operated properly.

- If using a ladder during assembly, use extreme caution.
- Two capable adults are recommended for assembly.
- Assemble the pole sections properly. Failure to do so could cause pole sections to separate during play or transport.
- Ensure that there are no overhead power lines within 7 m (20 ft.) radius of pole location.
- Minimum operational height is 1.98 m (6'6") to the bottom of the backboard.
- Check base daily for leakage. Leaks will cause system to fail.

Most injuries are caused by misuse and/or not following instructions.

Use caution when using this system.

2.1. Parts checklist

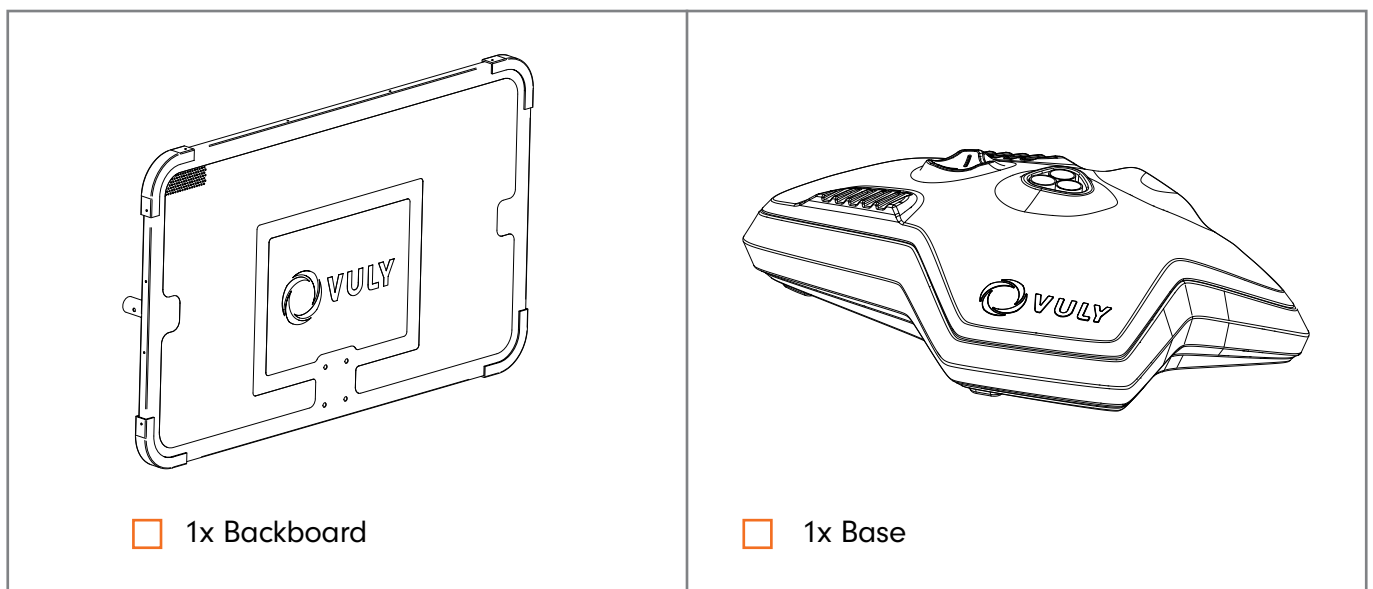



□ 2x Basketball Pumps



□ 1x ViperGrip Basketball

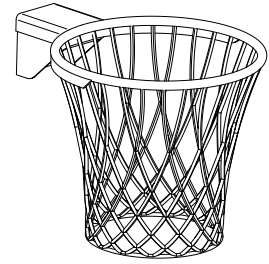

□ 1x Basketball Ring and Netting



□ 1x Telescoping Tube

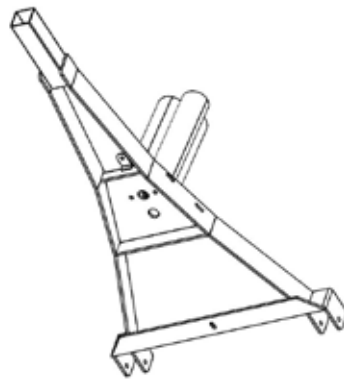

□ 1x Chassis (in Base)



□ 3x Wheels

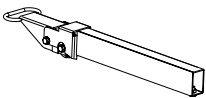

□ 1x Base Pull Unit

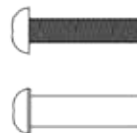

□ 22x M6 Locking Bolts



□ 2x M8 Chassis Bolts



□ 1x M8 Pull Unit Bolt

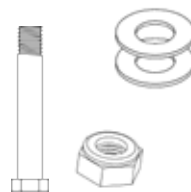

□ 2x M10 Front Wheel Bolts (70 mm)

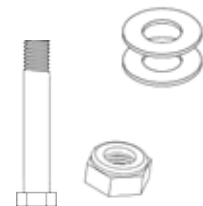

□ 1x M10 Rear Wheel Bolts (65 mm)

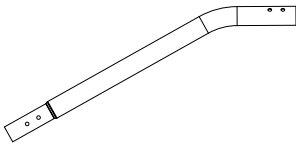

1x Left Tube A

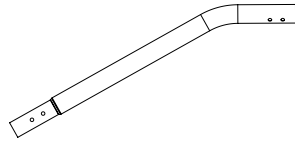

1x Right Tube A

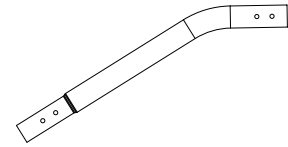

1x Centre Tube A

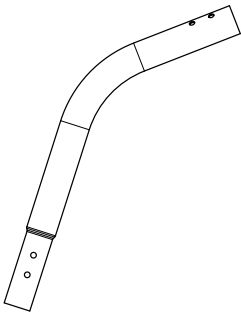

1x Left Tube C

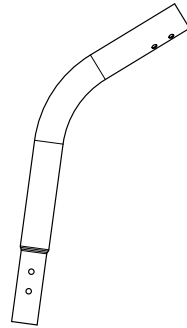

1x Right Tube C

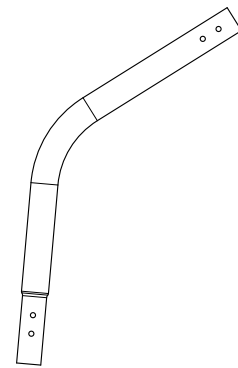

1x Centre Tube B



4x M10 Backboard Bolts

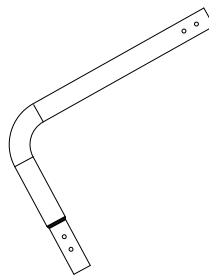

2x Left/Right Tube B

2.2. Assembly instructions – Vuly Slam Pro

Ensure that you assemble with two or more capable adults.

PRE-ASSEMBLY WARNING

Do not cut or remove the strap on the Telescoping Tube until directed to do so.

STEP | 1

- A. Remove all parts from the packaging, and lay out the components on the ground.
- B. Tip all nuts, bolts and tools into a container.

TWO PEOPLE:

- C. Flip the Chassis and Base upside down. Remove the two bolts that connect the Chassis to the Base, and separate these parts.

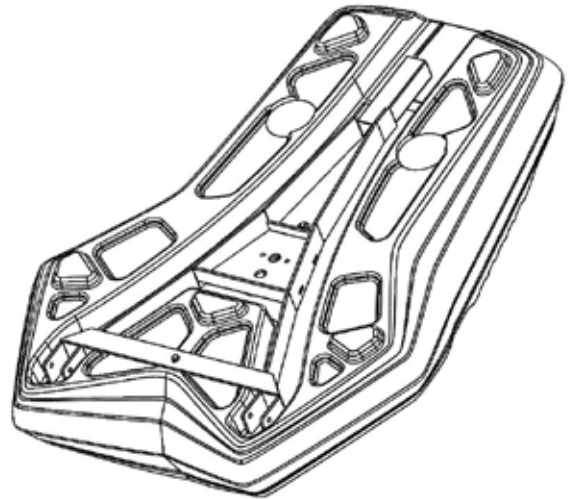

NOTE: Ensure that as you follow these instructions, you do **NOT** fully tighten nuts and bolts unless directed to do so.

When fully assembled, firmly secure all parts with nuts and bolts.

STEP | 2

- A. Slide the Base Pull Unit into the back of the Chassis. Take the M8 Pull Unit Bolt, insert it into the bottom of the Base Pull Unit and fully tighten.
- B. Take the M10 Rear Wheel Bolt and Nut (60 mm), and secure one Wheel to the Base Pull Unit.

NOTE: Ensure that you put washers on both sides and use spanners on both sides to fully tighten.

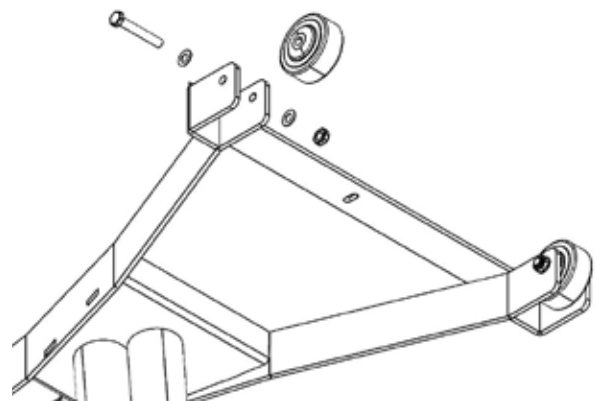

- C. Tip the Chassis forward, and take the M10 Front Wheel Bolts and Nut (75 mm). Secure both Wheels to the Chassis.

NOTE: Ensure that you put washers on both sides, insert the bolts from the outside-in and use spanners on both sides to full tighten.

STEP | 3

- A. Lift the Chassis, with Wheels now attached, back onto the overturned Base.
- B. Re-bolt the Chassis to the base, fully tightening the bolt and washer at the front of the unit first.
- C. Re-insert the bolt and washer in the middle of the Chassis, **but do not fully tighten (leave the washer loose)**.

WARNING: Overly tightening the centre bolt and washer may damage the unit and cause leakage.

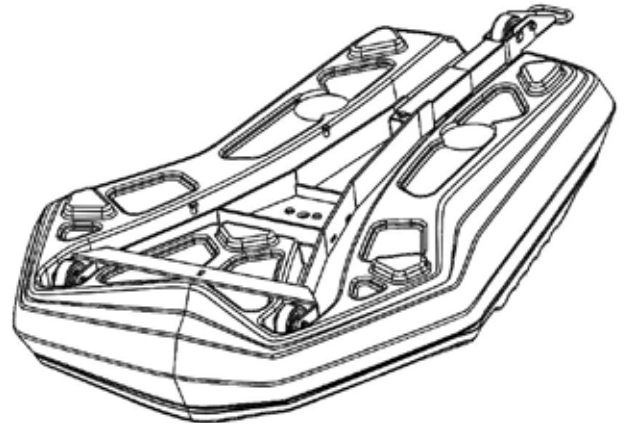

STEP | 4 TWO PEOPLE:

- A. Flip the now-assembled Chassis and Base the correct way up.
- B. Lift the Telescoping Tube and - front-pillar-first - slide into the Chassis and Base.

NOTE: Ensure that the handle is facing towards the rear of the Base.

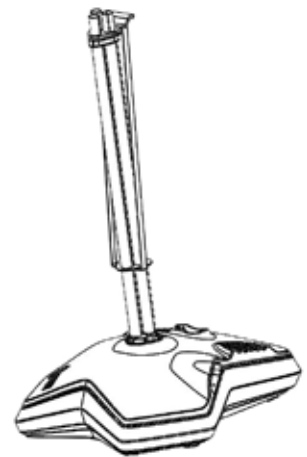

STEP | 5

Connect Left Tube A, Centre Tube A and Right Tube A into the left, centre and right points on the reverse of the Backboard.

Insert M6 Locking Bolts, but do not fully tighten them yet.

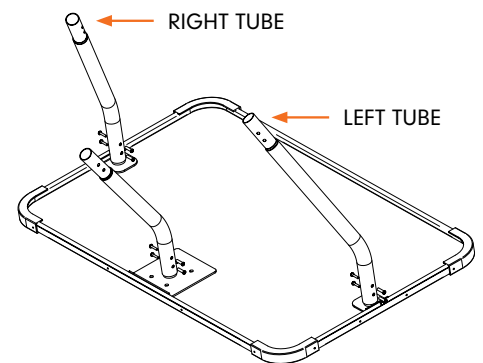

STEP | 6

Connect Left Tube B, Centre Tube B and Right Tube B into their corresponding Tube A.

Insert M6 Locking Bolts, but do not fully tighten them yet.

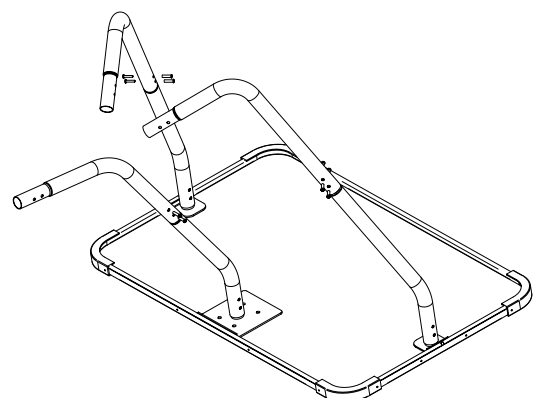

STEP | 7

Connect Left Tube C and Right Tube C into their corresponding Tube B.

Insert M6 Locking Bolts, but do not fully tighten them yet.

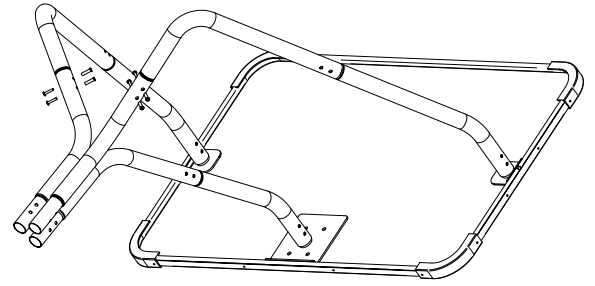

STEP | 8

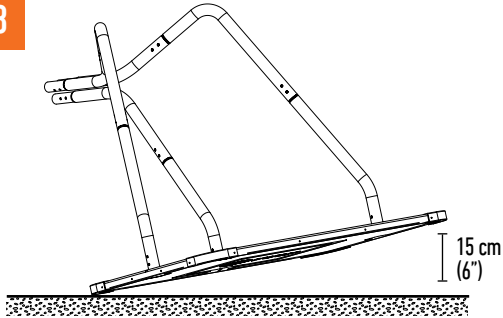

Position the Backboard above the Base, so that when tipped, the Base will meet the Backboard.

STEP | 9

Tip the Chassis and Base forward, insert the M8 Chassis Bolts and fully tighten.

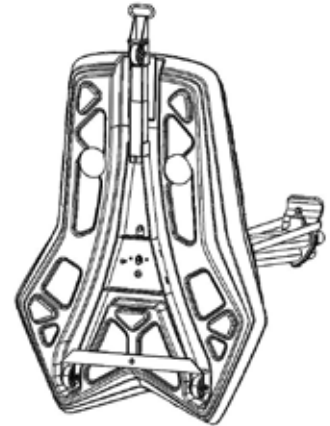

STEP | 10 TWO PEOPLE:

PERSON 1: Raise the top of the Backboard off the ground by about 15 cm.

PERSON 2: Tilt the Base and Telescoping Tube forwards carefully, until you can insert the Telescoping Tube into the Tubes on the Backboard. Connect them together.

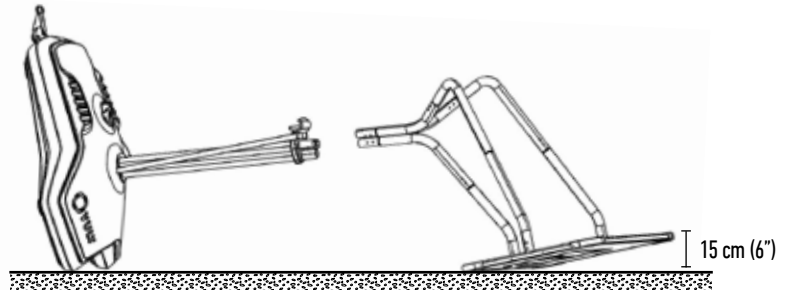

STEP | 11 TWO PEOPLE:

A. **PERSON 1:** Raise the connected Backboard, Telescoping Tube and Base back up, until fully upright.

Take a hose, and **at the entry point at the top of the Base**, fill the Base with water.

WARNING: Do not tamper with or remove the plug at the side of the Base.

PERSON 2: Hold the Base down firmly until Person 1 has filled it with water.

WARNING: Do not leave the Base unattended and upright while it is not filled with water (safety hazard).

B. Insert and fully tighten the M6 Locking Bolts.

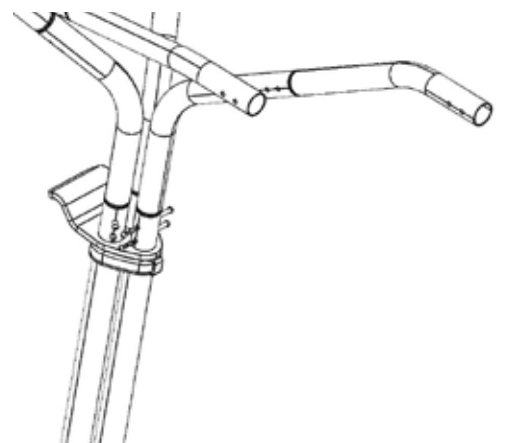

STEP | 12

Stand on a ladder and fully tighten all the M6 Locking Bolts on the Left, Centre and Right Tubes.

STEP | 13

Install the Basketball Ring and Netting onto the Backboard with the M10 Backboard Bolts.

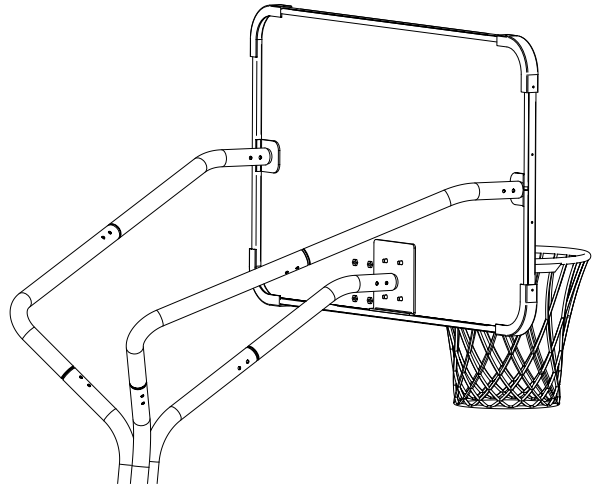

STEP | 14

- A. Cut and remove the white strap along the Telescoping Tube.
- B. Inflate your ViperGrip Basketball with the pump provided.

HOW TO SAFELY MOVE THE PORTABLE SYSTEM

- A. Ensure that you take the utmost care when moving your Slam Pro, and only move when the Base is filled with water.
- B. Unlock the locking mechanism on the Base Pull Unit by carefully pulling the handle out and upwards to raise the wheel.
- C. Position your Slam Pro as desired by gently pushing it by the Telescoping Tube, and lower the wheel again to lock.

NOTE: Consult a structural engineer if there is any doubt about the safety or stability of the installation.

CONGRATULATIONS!

You have assembled your Vuly Slam Pro!

3.0. Product registration

To access the Half-Price Parts for Life programme or to lodge a Warranty Claim, customers must ensure that their Vuly product is registered with Vuly.

Customers who purchase directly from Vuly (through VulyPlay.com, at the Vuly Showroom or over the phone) automatically have their product registered.

Customers who purchase through an Authorised Reseller must register their product by visiting VulyPlay.com/Support and completing the form with a proof of purchase.

4.0. Half-price Replacement Parts

Vuly offers half-price replacement parts to all customers for the lifetime of their trampoline purchase through the Half-Price Parts for Life programme.

This programme is subject to change at any time, and it is only available to customers who have purchased either through an Authorised Reseller or directly through Vuly.

Half-Price Parts for Life is only available to customers who wish to replace parts that are core components of their basketball hoop. For Slam Pro, these parts include:

- Backboard,
- Chassis and Base,
- Telescoping Tube,
- Left, Centre and Right Tubes,
- Basketball Ring.

The programme does not extend to accessories or to the ViperGrip Basketball and Mini Pump sold with Slam Pro.

5.0. Warranty

All Vuly products are sold with a manufacturing warranty, which assures that the item is free of defects in workmanship and materials ("warranty").

5.1. Warranty periods

Warranty periods do not reset for any reason, unless the customer purchases a new product. In this case, that particular item will be covered by its own warranty period. It does not affect – nor will it increase – warranty periods for other purchased items.

Warranty periods always commence from the date of item delivery, is for use under normal conditions and applies for:

Slam Pro

- 84 months [7 years] to all steel components – e.g. Backboard, Tubes, Chassis, Ring.
- 36 months [3 year] to all plastic and material components – e.g. Base, Netting.

Accessories

- 12 months [1 year] to the ViperGrip Basketball.
- 3 months to the Mini Pump.

5.2. Inclusions

This warranty covers manufacturing faults and defects only.

If a product is damaged or rendered unsafe as a result of a departure from its design specifications during production, this constitutes a manufacturing fault or defect.

This may occur if – for example – improper welding produces an Telescoping Tube.

5.3. Exclusions

5.3.1. Damage through wear and tear

This warranty does not extend to normal wear and tear of the product. This may include, but is not limited to:

- Rusting of steel components,
- Flaking of powder-coating on steel components;
- Fading of plastic components.

As outdoor products that are actively used, basketball hoops and their accessories will experience wear and tear over time.

5.3.2. Damage through weather conditions

Damage to the product that results from weather events – such as rain or wind – are not covered under the warranty. Vuly suggests that you contact your home and contents insurer if your basketball hoop is damaged by such events.

5.3.3. Damage through improper installation

This warranty does not extend to any failure of the product caused by installation not in accordance with the Vuly Manual. Customers must assemble their Vuly product by following carefully the Installation section of their Vuly Manual.

Furthermore, the warranty does not cover installation provided by a third-party assembly service. It is the customer's responsibility to check all boxes and confirm that all components are included in the correct condition before installing.

5.3.4. Damage through insufficient care or maintenance

This warranty does not extend to accelerated decay of the product caused by poor care or maintenance. It is essential that

customers regularly check, and follow the advice of, the Care, Maintenance and Use section of their Vuly Manual to ensure that their product lasts as long as possible.

5.3.5. Damage through inappropriate use

This warranty will be void if the product is used for any other activity besides those for which it was intended, or used in any way that is unadvised in this Manual. This Vuly product constitutes a recreational basketball hoops. It is not intended for use in a professional context.

Any evidence that inappropriate actions – such as hanging from the Ring – that have led to product failure will not be covered by the warranty. Similarly, replacement parts or repairs needed to mend such damage will not be covered under the warranty.

5.3.6. Damage through salt water proximity

This warranty (on steel components, specifically) will be reduced by 50% where the Vuly product is assembled within 1.6 km of a salt water environment or where it is subject to ocean spray.

5.3.7. Personal Injury

The warranty does not cover personal injury or losses due to any of the above: wear and tear, weather conditions, inappropriate installation, insufficient care or maintenance or inappropriate use, nor does it cover damage due to negligence or accidents.

5.4. Warranty claims

If a customer believes that a Vuly product is faulty or defective, they must discontinue use and submit a Warranty Claim.

A customer must not attempt to use a product if any part is faulty or defective, as it may be dangerous. Any damage that the user causes as a result of using faulty or defective products will lead to voiding of the warranty.

5.4.1. Making a Warranty Claim

To fulfill a warranty claim, a customer must submit an online Warranty Claim at VulyPlay.com/Support.

Submitting the online Warranty Claim form requires the customer to provide:

- Details of their purchase – including date,
- Batch number,
- Clear photographic evidence of the manufacturing fault or defect.

If the customer does not provide all details that the form requires, their Warranty Claim will not be assessed.

Vuly may take up to 7 days to process Warranty Claims upon a completed submission. It may take a further 7 days for replacement parts to reach the customer.

5.4.2. Successful Warranty Claims

If Vuly accepts a customer's Warranty Claim, Vuly will replace the faulty or defective parts, not offer refunds.

Successful Warranty Claims lodged within 60 days of the delivery date:

Vuly will replace the damaged parts free of charge. Vuly will also cover any costs associated with shipping the replacement part.

Successful Warranty Claims lodged after 60 days of the delivery date:

Vuly will replace the damaged parts free of charge. The customer must cover any costs associated with shipping the replacement part.

5.4.3. Walk-in Warranty Claims

If a customer wishes to make a Warranty Claim while on the Vuly premises, they must first submit an online Warranty Claim at VulyPlay.com/Support – providing all required details.

5.4.4. Refunds

In all instances of successful warranty claims, Vuly offers replacements parts only. Vuly provides refunds only at their discretion. Any refunds granted to the customer exclude third-party fees, such as assembly services and credit card surcharges.

5.4.5. Claiming on non-Vuly products

Products sold alongside Vuly that are not Vuly-branded are subject to the warranties provided by the companies that supply them. The customer must contact these external companies to make a warranty claim; Vuly itself will not assess claims made against non-Vuly products.

5.5. Australian Consumer Law

Our Goods come with guarantees that cannot be excluded under the Australian Consumer Law. You are entitled to a replacement or refund for a major failure and for compensation for any other reasonably foreseeable loss or damage. You are also entitled to have the Goods repaired or replaced if the Goods fail to be of acceptable quality and the failure does not amount to a major failure.

6.0. Missing parts

If a customer believes that a Vuly product does not include all necessary parts, they must immediately lodge a Missing Parts Claim at VulyPlay.com/Support.

A customer must not attempt to use a product if any part is incomplete, as it may be dangerous. Any damage that the user causes as a result of using incomplete products will lead to voiding of the warranty.

Vuly trampolines are delivered to Vuly warehouses prepackaged; we are unable to check the boxes prior to delivery to ensure that they contain all the required parts. While the missing part rate during packing is very low, some parts may also fall out in transit due to small, unintentional tears in their boxes.



See vulyplay.com/terms for the most recent Vuly warranty policies, terms and conditions.